

Manual

BeST™ LAMP Kit

Kit for isothermal DNA amplification in constant temperature.

catalog #	size
1025-100	100 reactions in 25 µl

For research use only.

Guarantee

A&A Biotechnology provides guarantee on this product.

The company does not guarantee correct performance of this kit in the event of:

- not adhering to the supplied protocol
- use of not recommended equipment or materials
- use of other reagents than recommended or which are not a component of the product
- use of expired or improperly stored product or its components



Table of Contents

Description	3
Contents	3
Notes	3
Additional equipment and reagents	3
Advantages of LAMP technique	4
Reaction setup	5
LAMP primers mix	5
DNA template	6
Setting the LAMP reaction	6
Experimental reaction	6
Control reaction (λ phage DNA template)	6
Isothermal amplification conditions	6
Detection of LAMP reaction	6

Description

LAMP (Loop Mediated Isothermal **AM**plification) is an isothermal nucleic acid amplification technique. In contrast to polymerase chain reaction (PCR) technology, which consists of repeated steps carried out in different temperatures, isothermal amplification is performed at a constant temperature and does not require a thermal cycler.

Contents

	1025-100	storage
2x BeST™ reaction mix	1 x 1.40 ml	-20 °C
BeST™ polymerase	1 x 120 µl	-20 °C
positive control		
λ phage DNA template λ primer mix	1 x 70 µl	-20 °C
ultrapure water	1 x 1.5 ml	-20 °C

Notes

- The reaction should be prepared on ice and tubes with reaction mix should be put immediately into a thermocycler or heating block preheated to 65 °C.
- A&A Biotechnology offers free help in designing primers for LAMP reaction as well as substantial help.

Additional equipment and reagents

- LAMP primers mix
- Ultrapure water for preparation of LAMP primers mix and DNA template suspension (cat. # 005-515, 005-1015, 005-2515, 005-5)
- TE buffer for DNA template suspension (cat. # K-TE-5, K-TE-100)

Advantages of LAMP technique

1. It allows for efficient and highly specific amplification of DNA by using three pairs of primers complementary to a suitable sequence of targeting DNA. Due to the specificity of primers the quantity of amplified DNA in the reaction is also considerably higher than in the PCR.
2. Fast amplification of DNA enables quick and easy identification of human, animal and plant pathogens - **detection time from 30 min to 1.5 hours** is dependent on the quality and concentration of the target DNA. In case of phage lambda DNA with a concentration range between 5–50 ng/μl the amplification time of the DNA sequence is less than 30 min.
3. BeST™ polymerase used in the LAMP reaction is a modified version of *Bst* polymerase from *Bacillus stearothermophilus*, lacking the 5'-3' exonuclease domain. In addition to a replication activity BeST™ polymerase has high strand displacement activity which eliminates denaturation of the DNA template.
4. The amplified products are concatemers of different sizes forming a ladder-pattern structure which could be detected by agarose gel electrophoresis or by monitoring the amplification in real time using fluorescent dye binding to double-stranded DNA or dyes sensitive to pH changes.

Reaction setup

Before starting the reaction:

1. LAMP primers mix

Prepare a 10x concentrated LAMP primer mix from 6 primers with final concentrations:
 16 μM FIP, 16 μM BIP, 2 μM F3, 2 μM B3, 4 μM LoopF, 4 μM LoopB - each suspended in water.

LAMP primers mix can be stored at -20 °C until later use.

Example of LAMP primer mix for a 150 μl reaction:

primer [100 μM]	FIB	BIP	F3	B3	Loop F	Loop B	water
volume	24 μl	24 μl	3 μl	3 μl	6 μl	6 μl	84 μl

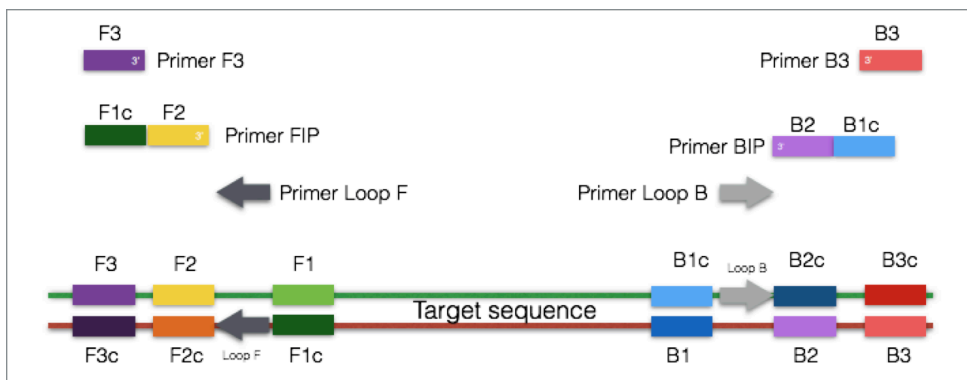

Fig. 1 Scheme of the LAMP primers system.

K+ K-



Fig. 2 Detection of LAMP products by agarose gel electrophoresis stained by EB (ethidium bromide).
 K+ LAMP reaction with λ phage DNA
 K- LAMP reaction without DNA template

NOTE: Primers desalted by precipitation are sufficient to carry out the LAMP reaction.

2. DNA template

DNA template should be suspended in water or TE buffer, pH 8.0 (not included).

Setting the LAMP reaction

Attention!!

The reaction should be prepared on ice and tubes with reaction mix should be put immediately into a thermocycler or heating block preheated to 65 °C.

1. Experimental reaction

component	volume
2x BeST™ Reaction Mix	12.5 µl
DNA template [0.01-500 ng]	1 µl
LAMP primers mix	2.5 µl
BeST™ polymerase	1 µl
ultrapure water	up to 25 µl

Gently mix by vortexing and briefly centrifuged.

2. Control reaction (λ phage DNA template)

component	volume
2x BeST™ Reaction Mix	12.5 µl
positive control	4 µl
BeST™ polymerase	1 µl
ultrapure water	up to 25 µl

Gently mix by vortexing and briefly centrifuged.

3. Isothermal amplification conditions

temperature	time
65 °C	30 min
10 °C	∞

In case of first use of the kit it is recommended to optimize the reaction by analysis of the LAMP reaction products after 30, 60 and 90 minutes.

Detection of LAMP reaction

The DNA analysis after the LAMP reaction should be carried out by electrophoresis agarose gel. We recommend electrophoresis on 1.5% agarose gel with ethidium bromide to the degree of separation indicated on Fig. 2. (page 5).



A&A BIOTECHNOLOGY
innovating life science

A&A Biotechnology, ul. Strzelca 40, 80-299 Gdańsk, Poland
phone +48 883 323 761, +48 600 776 268
info@aabiotech.com, www.aabiotech.com

version 2025-1

